



**Made in Britain**

# **FIXED-UFM Ultrasonic Flowmeter**

## **Installation Manual**

**Version 4.0**



**13th March 2023**

**Copyright Sonic Driver Ltd 2023**

# Contents

## 1.0 Introduction

- 1.1 Transit Time Measurement
- 1.2 Packing List
- 1.3 General Precautions
- 1.4 Cleaning
- 1.5 Connecting the Flow Transducers
- 1.6 Mounting the Flow Transducers
- 1.7 Mounting the UFM
- 1.8 Wiring the UFM
- 1.9 Turning the UFM On

## 2.0 Using the Quick Start Sequence

- 2.1 Transducer Menu
  - 2.1.1 Type
  - 2.1.2 Mounting
- 2.2 Pipe Menu
  - 2.2.1 Outer Diameter
  - 2.2.2 Wall Thickness
  - 2.2.3 Material
  - 2.2.4 Sound Velocity
- 2.3 Liner Menu
  - 2.3.1 Material
  - 2.3.2 Sound Velocity
  - 2.3.3 Thickness
- 2.4 Fluid Menu
  - 2.4.1 Type
  - 2.4.2 Temperature

## 3.0 Sensor Positioning

- 3.1 Optimising Transducer Mounting Location
- 3.2 Upstream and Downstream Pipe Runs
- 3.3 Transducer Mounting
- 3.4 Transducer Spacing

## 4.0 Heat Metering

## 5.0 Error Codes

## 6.0 Icons

## 7.0 Specification

## 8.0 Product Identification

## 9.0 Service

## 10.0 Limited Warranty and Disclaimer

**Appendix A Contact Details**

**Appendix B Table of fluid properties**

**Appendix C Table of pipe and lining material properties**

**Appendix D Table of speed of sound in water**

**Appendix E Table of typical pipe roughness values**

## 1.0 Introduction

Congratulations on choosing the Sonic Driver FIXED-UFM clamp-on ultrasonic flowmeter, figure(1).



**Figure(1) The Sonic Driver FIXED-UFM.**

The ultrasonic flowmeter (UFM) uses advanced Digital Signal Processing (DSP) and transit time measurement techniques (Sonic Driver™) to make accurate and reliable clamp-on ultrasonic flow velocity measurements on liquids flowing in closed pipes

Using information about the installation, entered by the user, using the meters intuitive and easy to use menu driven User Interface (UI) the UFM can display;

- Flow velocity
- Volumetric flow rate
- Mass flow rate
- Heat quantity flow rate

When making heat measurements the UFM uses the calculation method outlined in EN1434-1 section 8 and its appendix A.

The UFM comes in 3 different versions;

- Standard - outer pipe diameter ranged 10.0 to 115.0mm
- Medium - outer pipe diameter ranged 115.0 to 225.0mm
- Large - outer pipe diameter ranged 225.0 to 6500.0mm

## 1.1 Transit Time Measurement

The principle of flow measurement using ultrasonic clamp-on transit time measurement is simple, see figure(2).

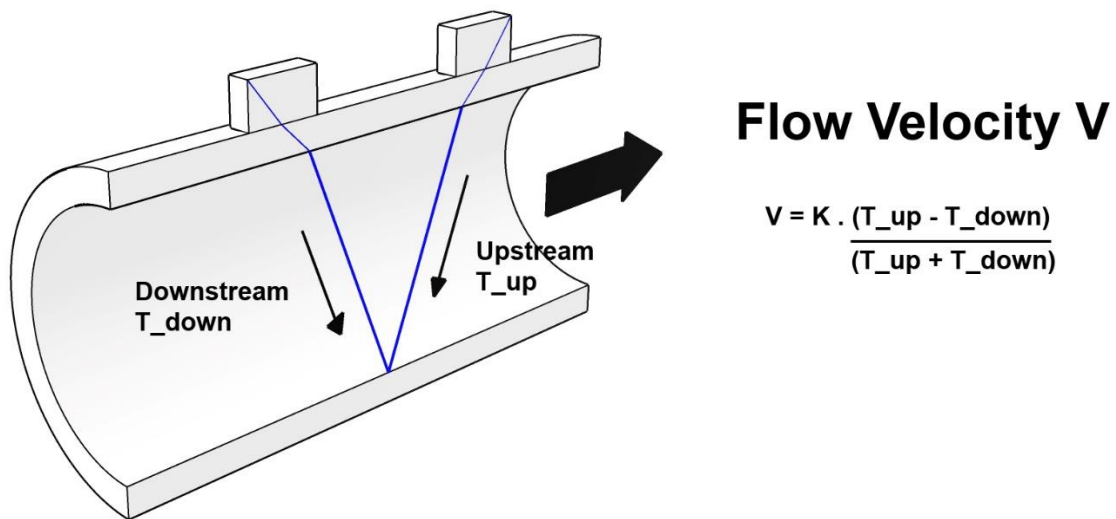

**Figure(2) The principle of transit time flow measurement.**

Two ultrasonic transducers are coupled or clamped to the outside of the pipe at a predetermined distance apart.

Ultrasonic pulses travel between the transducers through the pipe wall and the fluid within the pipe.

If the fluid is flowing then it takes slightly longer for the ultrasound to travel against the flow (upstream time  $T_{up}$ ) than with the flow (downstream time  $T_{down}$ ), see figure(2).

In a typical installation the individual times measured upstream and downstream are just a few hundred microseconds, the difference between them is typically measured in tens of nanoseconds.

This very small time difference ( $T_{up} - T_{down}$ ) is measured by the UFM and is directly proportional to the flow velocity ( $V$ ) of the fluid.

Knowing the pipe internal cross-sectional area the UFM can calculate volumetric flow rate in many common engineering units. A further knowledge of the density of the fluid allows the UFM to calculate mass flow rate.

Finally, a knowledge of inlet and outlet fluid temperature and Specific Heat Capacity of the fluid allows the UFM to calculate heat flow rate.

All of these rates can be totalled and positive, negative and net values displayed.

## 1.2 Packing List

Within the UFM packaging you should find;

Item	Quantity
FIXED-UFM	1
PEEK/Stainless Steel Flow Transducer	2
Chain Mounting Clamp	2
Tape Measure	1
Coupling Gel	1

**Table(1) Packing List.**

If any item on the packing list is missing or has been damaged in transit contact Service, see Appendix A.

## 1.3 General Precautions

The content of this manual has been carefully checked and is believed to be accurate.

Sonic Driver Ltd assumes no responsibility for any inaccuracies that may be contained in this manual.

In no event will Sonic Driver be liable for direct, indirect, special, incidental or consequential damages resulting from any defect or omission in this manual, even if we are advised of the possibility of such damages.

Sonic Driver Ltd reserves the right to make improvements to its manuals, instructions and products at any time, without notice or obligation. The latest revisions may be found on the company web site, see appendix A.

The UFM is a precision measuring instrument and should be handled and operated with care;

- Before operating the UFM for the first time read the installation manual and operating instruction fully.
- Only use the UFM in the way and for the purpose that it is intended.
- Do not subject the UFM to bumps and shocks such as caused by dropping the UFM.
- Keep the UFM and its transducers and probes clean.
- Only use the UFM within its ambient temperature and stated level of Ingress Protection.
- Avoid excessive stress and bending of transducer cables and connectors.
- Avoid striking the clear display window and keypad with sharp objects.

## 1.4 Cleaning

Wipe the UFM and sensors with tissue or soft cloth after use, remove excess coupling gel.

## 1.5 Connecting the Flow Transducers

Connect the flow transducers to the screw terminal connectors in the screw terminal compartment of the UFM, see figure(3).

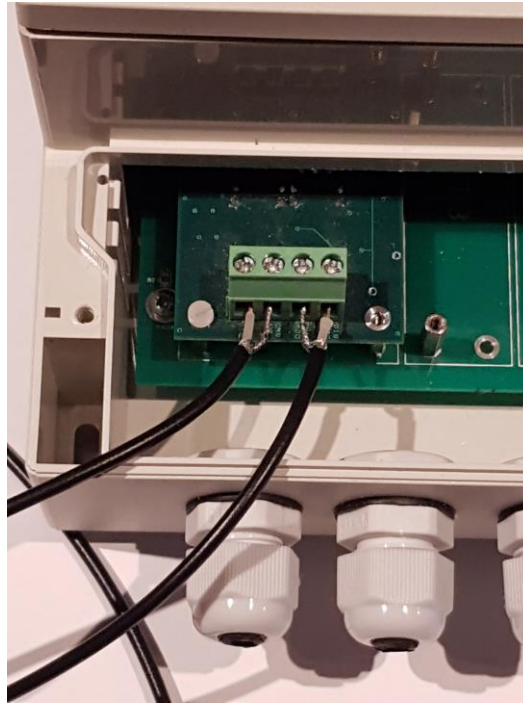

**Figure(3) Flow transducer connection.**

The left-hand screw terminals connect the flow transducer which is mounted on the pipe downstream, the right-hand screw terminals connect the flow transducer which is mounted upstream.

## 1.6 Mounting the Flow Transducers

Mount the flow transducers on the pipe using the chain clamps supplied, see figure(4). Ensure that the arrow on the labels (arrowhead and flights) on the flow transducers is pointing in the direction of flow.

Use coupling gel between the transducers and the pipe to give good ultrasonic contact.

Measure the spacing of the transducers using the tape measure provided, note that spacing is measured between the front faces of the transducers. Ensure the transducers are facing each other and aligned axially along the pipe.



**Figure(4) Flow transducer mounting, spacing is 25mm between front faces.**

In figure(5) and figure(6) the transducers are misaligned and twisted, as a result the UFM will make poor flow measurements.



**Figure(5) Misaligned transducers.**



**Figure(6) Twisted transducers.**



## 1.7 Mounting the UFM

When wall mounting the UFM refer to Figure(7),

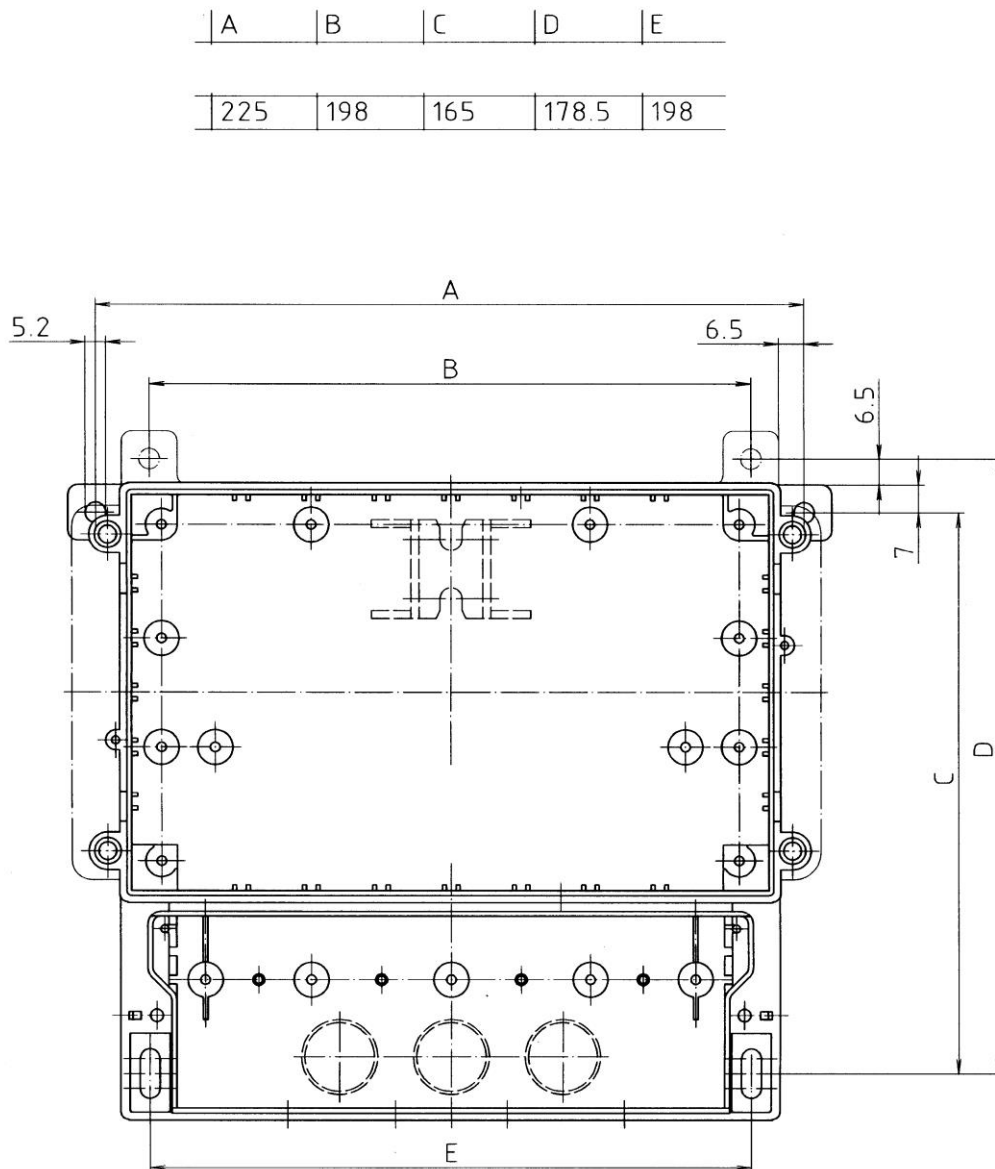

**Figure(7) Wall mounting the UFM.**

## 1.8 Wiring the UFM

To power on the UFM simply apply AC or DC power as appropriate to the model.

Always disconnect the mains supply before removing any covers and connecting any external wiring to the UFM. Only qualified Electricians should install the UFM and IET BS7671:2008 wiring regulations must be adhered to.

Always install a ground fault interrupt circuit (GFIC)/residual current circuit breaker (RCCB) with a maximum trigger current of 30 mA.

If installed outside, provide over voltage protection through an MCB rated not greater than 5 Amps.

With fixed wiring, a disconnecting device (local interruption) must be integrated into the power supply line. The disconnecting device must meet BS7671:2008 standards and regulations. It must be installed near the device, be able to be reached easily by the operator and labelled as a disconnecting device.

## **1.9 Turning the UFM On**

To power on the UFM simply apply AC or DC power as appropriate to the model.

As soon as the UFM is switched on a self-diagnostic program will start. If an error is detected an error message will be displayed prompting user action. If the error persists, contact customer support.

See relevant sections on Input/Output and Datalogger below for more detail of what tests are carried out.

Error codes and their meanings can be found in the Diagnostics Menu.

## 2.0 Using the Quick Start Sequence

Once powered on the UFM will be in UI mode displaying the Main Menu.

The Main Menu allows the user to select a group of parameters to edit or a meter function;

- Quick Start
- Installation
- System Settings
- Diagnostics
- Input/Output
- RS232/USB
- Datalogger
- Batching
- Manual Totaliser
- Phase Detection
- Heat Metering

The Quick Start function takes the user through the minimum sequence of parameters needed to get the UFM measuring reliably and accurately;

- Pipe Outer Diameter
- Pipe Wall Thickness
- Pipe Material
- Liner Material
- Fluid Type
- Fluid Temperature
- Transducer Type
- Transducer Mounting

Each parameter is described below in the relevant section.

## **2.1 Transducer Menu**

This menu allows the user to change transducer settings.

### **2.1.1 Type**

The user is prompted to select the type of sensors mounted on the pipe from a list;

- DS05
- DS10
- DS20
- DS40
- DM10(Default)
- DM20
- DN40
- Flow Other

DM sensors are Sonic Driver standard PEEK/stainless steel design. DN sensors are Sonic Driver small pipe design. DS sensors are Sonic Driver large pipe design.

If Flow Other is selected, then the user will be prompted to enter detailed transducer specific information.

The ability to select Flow Other is intended for use when using the UFM with special sensors supplied by Sonic Driver.

### **2.1.2 Mounting**

The user is prompted to select the sound path in the pipe from a list;

- Auto (Default)
- Z
- V
- N
- W
- 5
- 6
- 7
- 8
- 9
- 10
- 11
- 12
- 13
- 14

Selecting Auto means that the UFM determines for itself which sound path to use.

Ideally choose a number of passes that results in a path length in the fluid of 100mm or greater.

- Z or 1 pass, most common on large diameter pipes, typically 100mm or more in diameter. If the UFM suggests a negative spacing, then this is measured as in figure(8).

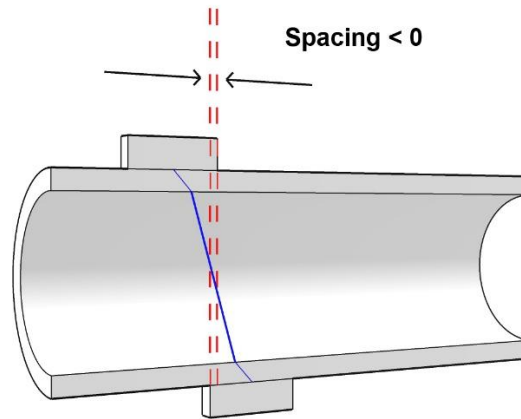

**Figure(8) Z or 1 pass, demonstrating a negative transducer spacing.**

- V or 2 passes, the most commonly used method, this is the simplest to install as both sensors are on the same side of the pipe, see figure(9).

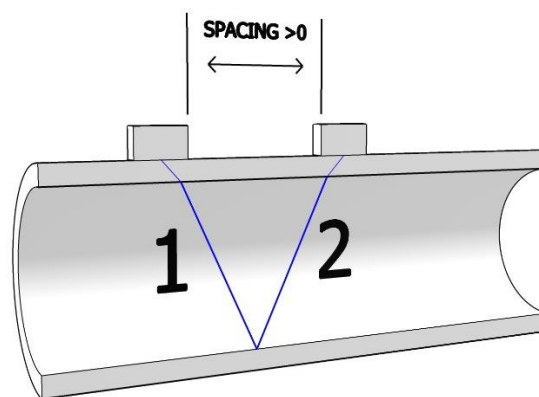

**Figure(9) V or 2 passes.**

- N or 3 passes, used on small diameter pipes.
- W or 4 passes, used on the smallest diameter pipes, see figure(10).

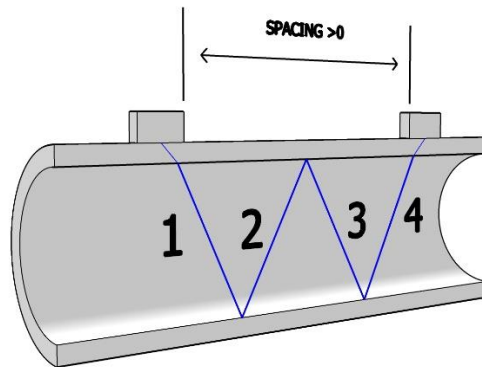

**Figure(10) W or 4 passes.**

- 5 to 13 and 14, etc.

It may be that on the smallest diameter pipes then the recommended transducer spacing at 14 passes is not sufficient to allow the transducers to be coupled on the same side of the pipe, using an even number of passes as they still touch. In this case it is unavoidable to couple the transducers on opposite sides of the pipe using an odd number of passes, for example 11 or 13 passes.

## 2.2 Pipe Menu

The following parameters allow the user to specify the pipe.

### 2.2.1 Outer Diameter

The user is prompted to enter a value for the pipe outer diameter. The UFM comes in 3 different versions;

- Standard - Allowed values are ranged 10.0 to 115.0mm
- Medium - Allowed values are ranged 115.0 to 225.0mm
- Large - Allowed values are ranged 225.0 to 6500.0mm

For each size the default is 60.6mm.

### 2.2.2 Wall Thickness

The user is prompted to enter a value for the pipe wall thickness. Allowed values are ranged 0.5 to 100.0mm, default 3.2mm.

### 2.2.3 Material

The user can select the pipe material from a list;

- Carbon Steel (Default)
- Stainless 304
- Stainless 316
- Cast Iron
- Ductile Iron
- Copper
- PVC
- Lead
- Nylon
- PE
- Aluminium
- Asbestos
- Fibre Glass
- Other

If Other is selected then the user is prompted to enter the transverse (shear) speed of sound in the pipe material, see below. Otherwise the transverse speed of sound in the pipe material is read from a database held in the UFM.

### 2.2.4 Sound Velocity

Appearance of this parameter is context driven. If the user selected Other from the list of pipe materials, then the user is prompted to enter the transverse speed of sound in the pipe material. Otherwise the speed of sound in the pipe material is read from a database held in the UFM.

Allowed values are ranged 500 to 7000m/s, default 3206m/s (Carbon Steel).

## **2.3 Liner Menu**

This menu allows the user to change pipe lining settings.

### **2.3.1 Material**

The user can select a pipe liner material from a list;

- None (Default)
- Cement
- Epoxy
- Glass
- PP
- Teflon
- Rubber
- Other

The list allows no liner (None) to be selected.

### **2.3.2 Sound Velocity**

Appearance of this parameter is context driven. If the user selected Other from the list of liner materials, then the user is prompted to enter the transverse speed of sound in the liner material. Otherwise the speed of sound in the liner material is read from a database held in the UFM.

Allowed values are ranged 500 to 7000m/s, default 0m/s (None).

### **2.3.3 Thickness**

Appearance of this parameter is context driven. If the user selected a liner, then the user is prompted for the thickness of the liner. Allowed values are ranged 0.5 to 100.0mm, default 0.0mm (None).



## **2.4 Fluid Menu**

This menu allows the user to change fluid settings.

### **2.4.1 Type**

The user can select the fluid in the pipe from a list;

- Water (Default)
- Sea Water
- Kerosene
- Petrol
- Fuel Oil
- Crude Oil
- Freon R134a
- Freon R22
- Diesel Oil
- Castor Oil
- F776 Fuel Oil
- Novec 1230
- Glycol/Water
- Alcohol
- Other

If the user selected Other from the list of fluid types then the user is prompted to enter various other context driven parameters including; Fluid Sound Velocity, Fluid Kinematic Viscosity and Fluid Density.

### **2.4.2 Temperature**

The user is prompted to enter the temperature of the fluid in the pipe. Allowed values are ranged -20 to +150 degC, default 18 degC.

Changing Fluid Temperature causes Fluid Sound Velocity, Fluid Kinematic Viscosity, Fluid Density and Fluid Specific Heat Capacity to be recalculated.

### 3.0 Sensor Positioning

After completing entry of all parameters in the Quick Start function sequence the user is prompted to confirm Transducer Type and is then taken to the Sensor Positioning screen.

Using the entered parameters the UFM calculates and gives the required transducer spacing on the pipe. The screen also displays the number of passes selected by the user or calculated by the UFM if in Auto Passes mode.

The user is then presented with a sensor positioning screen showing,

- Graph of received ultrasonic signal
- Calculated sensor spacing
- Number of sound passes in the pipe
- Signal to Noise Ratio
- ATA/ETA

If the parameters entered are all correct, then the graph should appear as in figure(11).

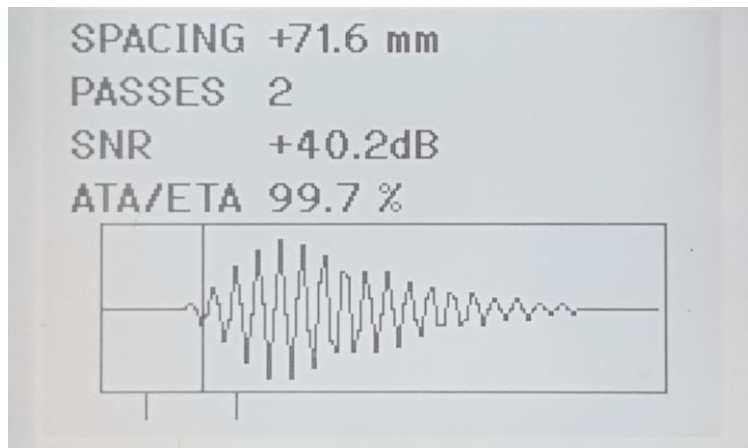

**Figure(11) Ideal Sensor Positioning.**

However, if the user has an incomplete knowledge of the pipe then the screen may look like figure(12) or figure(13).

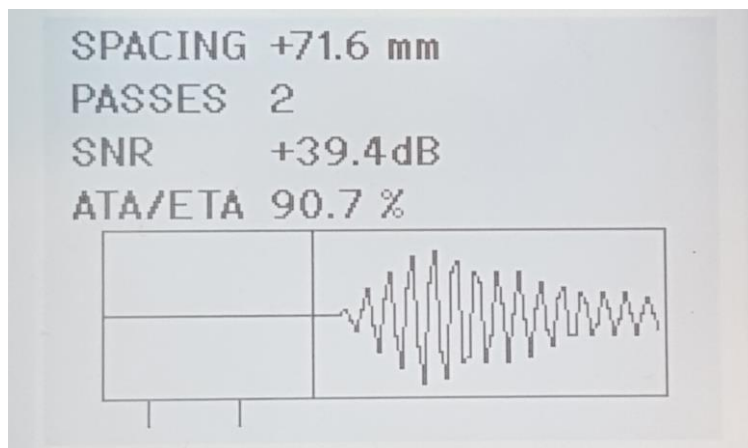

**Figure(12) Non-ideal Sensor Positioning, transducers too far apart.**

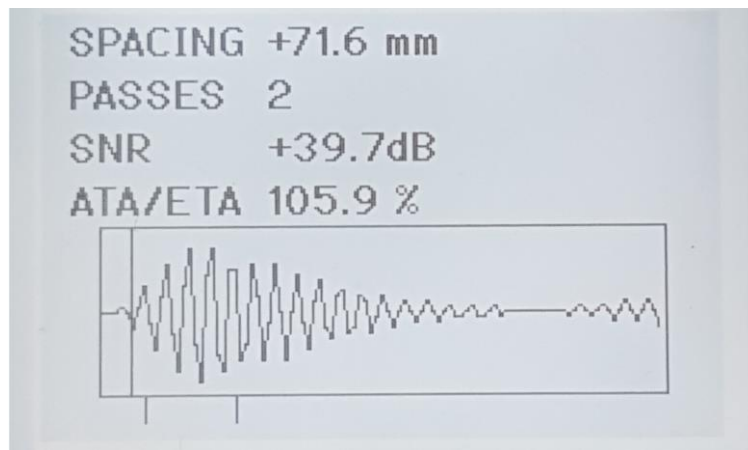

**Figure(13) Non-ideal Sensor Positioning, transducers too close together.**

In figure(12) the received signal is too far to the right, the user should slide the transducers closer together.

In figure(13) the received signal is too far to the left, the user should slide the transducers further apart.

The most common cause of an incomplete or incorrect spacing is a lack of knowledge about the pipe wall thickness.

As long as the vertical line acting as arrival marker is between the 2 guide marks, resulting in an ATE/ETA value between 97 and 103% then the UFM will measure accurately. It is acceptable to reposition the transducers to adjust their spacing by +/- 5 mm to optimise the positioning screen, the arrival marker will move on the screen accordingly.

SNR should peak and be above 24 dB.

### 3.1 Optimising Transducer Mounting Location

For the best results ensure that,

- Ideally the transducers are mounted on bare pipe material, for metal pipes this should be metal free from dust, rust and paint.
- Consider a location away from internal corrosion, sediment and streams of entrained air, do not mount the transducers top to bottom on the pipe, mount at 2 or 10 o'clock.
- Avoid mounting the transducers either on or opposite axial welds along the pipe.
- Ensure the transducers are aligned axially along the pipe.
- Mount the transducers away from bends, valves and other inserted instrumentation.
- Observe where practical the advised upstream and downstream straight sections, see below, figure(14).
- Ensure the pipe will always be full at the point of installation, ideally mount the transducers at a low point in the system.
- If mounting the transducers on a vertical pipe section ensure the flow direction is upwards in the section.
- Composite pipes can have de-laminations in their wall thickness, this type of pipe is notoriously bad when installing a UFM.
- Ensure the temperature at the transducer location is within the transducers rated range.

- Ideally the fluid should be free of particulates and bubbles, in the limit then an alternative method such as Doppler flow measurement may be required.
- Pipe linings that are not bonded properly or are not conductive of ultrasound (rubber) will cause measurement problems.
- Porous pipes, such as concrete can cause measurement problems.
- Using information from Standard Pipe Tables can be inaccurate, it is always best to measure the pipe outer diameter and wall thickness.
- No matter how accurate the meter is at making a velocity measurement, an inaccurate knowledge of the internal cross-sectional area of the pipe will lead to inaccuracy in the conversion to volumetric flow rate.

### 3.2 Upstream and Downstream Pipe Runs

Ideally the UFM transducers should be installed on as long a section of straight pipe as is possible, see figure(14).

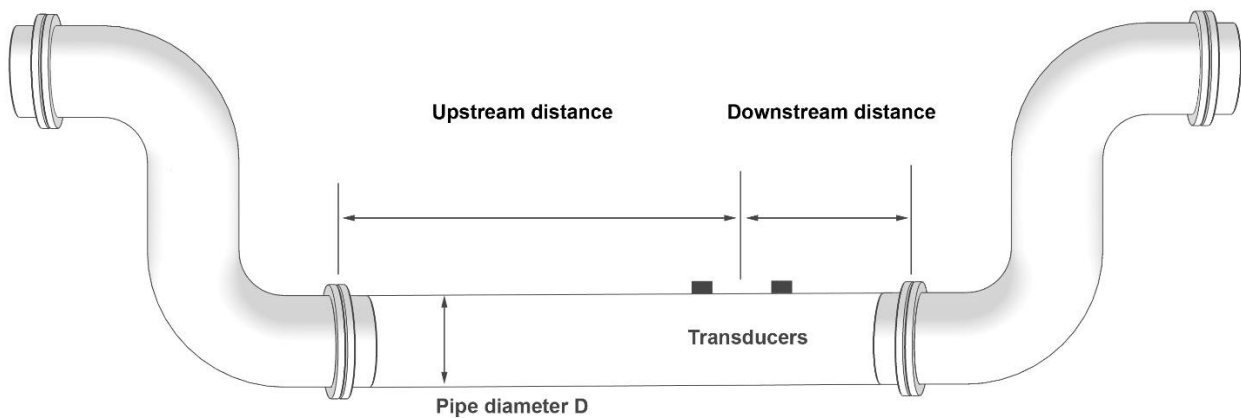

**Figure(14) Upstream and downstream pipe lengths.**

Considering a pipe with an outer diameter of  $D$  then if possible ensure at least  $10D$  upstream distance between the transducers and a bend in the pipework.

In the case of an upstream Valve then if possible ensure at least  $20D$  upstream.

In the case of an upstream Pump then if possible ensure at least  $30D$  upstream.

In all cases ideally ensure  $5D$  downstream exists before a bend or obstruction in the pipework.

### 3.3 Transducer Mounting

Locate an optimum position on the pipe following the advice above.

Use Coupling gel. Apply adequate couplant and ensure no gap exists between the transducer and the pipe surfaces.

Banding or clamping is required to keep the transducers in place. It is recommended to use chain

clamps or 10mm wide jubilee clips.

### **3.4 Transducer Spacing**

Given that all information regarding the installation has been entered accurately and the advice above has been followed then the UFM will measure reliably and accurately.

This is confirmed by,

- A strong received signal strength
- A high SNR value
- Value of ATA/ETA close to 100%

It is acceptable to make small adjustments to the transducer spacing to optimise the received signal strength and ATA/ETA.

However, if large adjustments are necessary then the importance of wall thickness should be considered. Wall thickness is typically the parameter about which the user has the least knowledge.

If all other avenues have been explored, including recoupling the transducers at several different locations on the pipework then adjusting the wall thickness parameter may help.

## 4.0 Heat Metering

Heat meters measure the energy necessary to provide hot water or cooling to a location such as a building or room.

The meter measures the energy on the supply or return side of a heating (boiler) or cooling (chiller) device by measuring the flow rate of heat or cooling fluid and the temperature difference between the supply and return legs of the system.

The pipe from the source of heat or cooling entering a location is known as the Flow or inlet pipe.

The pipe from the location returning to the source is known as the Return or outlet pipe.

The meter is programmed to be installed on the return pipe. This is the colder pipe for heating systems and the warmer pipe for cooling systems.

With the addition of PT100 plug-in modules for real-time measurement of inlet and outlet temperature the UFM can function as a heat meter.

For a boiler heating installation the flow measurement needs to be made on the cold side of the system.

For a chiller cooling installation the flow measurement needs to be made on the warm side of the system.

If the correct meter installation position is not used and/or the temperature sensing elements are not placed on the correct flow/return legs then a meter may be up to 10% inaccurate.

### Calculation Method

This list allows the user to select how heat measurements are made;

- SHC (Default)
- EN1434-1
- GSSSD

The default calculation uses Specific Heat Capacity, mass flow and temperature difference between inlet and outlet to make the heat calculations.

EN1434-1 uses calculations defined in the standard section 8 and appendix A. Uses specific volume and enthalpy to make the heat calculations.

GSSSD makes calculations as defined by the Russian standard. Uses enthalpy, density and pressure to make the heat calculations.

### Pressure

This value, in MPa is only used as part of the GSSSD method.

Allowed values are ranged 0.05 to 30.0MPa, default 0.1MPa.

## **Specific Heat Capacity**

The UFM can make energy calculations using the Specific Heat Capacity (SHC) method, where the user must manually enter values for pipe inlet and outlet temperature.

The user can enter a value for the Specific Heat capacity of the fluid flowing in the pipe. Allowed values are ranged 0.0 to 10.0J/(g.K), default 4185.6J/(g.K) (Water at 18degC).

## 5.0 Error Codes

As soon as the UFM is switched on a self-diagnostic program will start. This program fully tests both the UFM hardware and software.

If an error is detected an error message will be displayed prompting user action. If the error persists contact customer support, see appendix A.

Error codes and their meanings can be found in the Main Menu under the Diagnostics Menu.

- RTC, there is a problem with the UFM real time clock IC.
- MATH, there is a problem with the UFM central maths processor.
- STACK, there is a stack overflow problem.
- ADDR, there is a memory addressing problem.
- OSC, the UFM core oscillator is suffering a problem.
- SPI1, there is a problem with the internal SPI1 data bus.
- SPI2, there is a problem with the internal SPI2 data bus.
- I2C2, there is a problem with the internal I2C2 data bus.
- FRAM, there is a problem with the UFM external FRAM memory.
- FLASH, there is a problem with the UFM external FLASH memory.
- TEMP, there is a problem with the UFM internal temperature measuring IC.
- TOFM, there is a problem with the UFM core ultrasonic measuring module.
- TIMING, there is a problem with the UFM measurement sequence.
- IO, there is a problem with the UFM communicating with IO modules.

The diagnostics menu also lists the optional plug-in IO modules currently fitted in the UFM and configurations for serial communications; baud, bits, parity, etc.

## 6.0 Icons

The UFM has a series of icons along the bottom of the LCD and in the top right corner. The meanings of these icons are from left to right as they appear;

- SND, Audio buzzer on/off.
- LCD, LCD backlight on/off.
- CLK, RTC or timing error.
- DAT, Serial data streaming via RS232 or USB port.
- LOG, Datalogger is active.
- ERR, Serious microprocessor internal error.
- WARNING TRIANGLE, an error code is active, check installation.

and in the top right corner;

- ! MARK, Low signal strength, high noise and/or poor signal to noise ratio, measurements may be unreliable, check installation.

The LCD also shows date, bottom left and time bottom right when in measurement mode.



In addition to showing icons, depending on the flow regime, see figure(15) the UFM displays;

- Zero, no flow
- Lam, laminar
- Trans, transition
- Turb, turbulent

in the top-left of the display when in measurement mode.

Laminar flow is generally regarded to exist for Reynolds Number less than 2300, transition is in the range 2300 to 4000 and turbulent flow typically has a Reynolds Number greater than 4000.

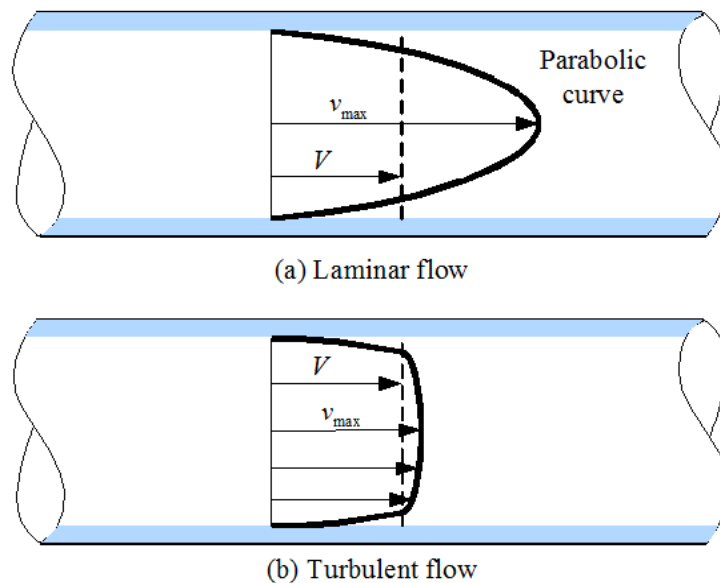

**Figure(15) Laminar (a) and turbulent (b) flow.**

## 7.0 Specification

The UFM specification, features and performance are listed below;

- Pipe outer diameters ranging from 10 to 6500 mm in 3 versions
  - Standard - outer pipe diameter ranged 10.0 to 115.0mm
  - Medium - outer pipe diameter ranged 115.0 to 225.0mm
  - Large - outer pipe diameter ranged 225.0 to 6500.0mm
- Temperature range for control unit -10 to +65 degC.
- Weight 840 g.
- Dimensions 215 x 185 x 100 mm.
- IP65 enclosure.
- Full 240 x 160 pixel graphics display with backlight.
- Full 15 key tactile keypad with audio feedback.
- Available in both 85 to 265Vac and 12 to 24Vdc PSU configurations at 10W.
- RS232 and USB serial communications as standard.
- 16MB datalogger as standard. All measurement values can be logged. User selected interval from 1 to 255 s.

## Features

- Intuitive installation using menu driven UI.
- Full set of instrument and measurement diagnostics.
- Signal oscilloscope for sensor positioning and diagnostics.
- Internal database of pipe, fluid and lining materials.
- Fluid database of sound speed, density, viscosity and SHC compensated for fluid temperature (if temperature is known from optional PT100 or 0/4 to 20mA temperature transmitter input)
- Heat quantity measurement (if inlet and outlet temperatures are known from optional PT100 inputs, 0/4 to 20mA temperature transmitters or direct user entry).
- All measured values can be totalled.
- Connection to PC using both RS232 and built in USB.
- Serial communications can be used for device control (command line interface) and datalogger download via PC.
- Batching functionality.
- Manual totaliser functionality.
- Product identification functionality. Can be used for a range of processes including oil dewatering.
- Heat metering functionality.

## Performance

- Measurement principle ultrasonic transit time difference.
- Flow velocity range 0.01 to 25 m/s.
- Resolution 0.25 mm/s.
- Repeatability 0.15% of measured value.
- Accuracy +/- 1 to 3% of measured value depending on application, +/- 0.5% of measured value with process calibration against reference meter.
- Turn down ratio 1/100.
- Measurement rate 1Hz as standard.
- Gas/solids <10% of volume.

## Quantity and units of measurement

- Flow velocity
- Volumetric flow rate
- Mass flow rate
- Energy flow rate
- Volume
- Mass
- Energy

## Optional plug in IO modules

- Galvanic and optical isolation.
- Namur levels for signalling.
- 16 bit resolution.

Currently available modules include:

- Active 4 to 20mA current output.
- Passive 4 to 20mA current output.
- Active 4 to 20mA current input.
- Passive 0/4 to 20mA current input.
- Open Collector pulse (user selected duration 3 to 999 ms).
- Opto Relay pulse.
- Relay (NO and NC) output.
- PT100 input (4 wire).
- Modbus RTU.

## Transducers



**Figure(16) PEEK/stainless steel transducers.**

- A range of sensor sizes to cover the range of pipe outer diameter 10 to 6500mm.
- DS, for pipes of 50mm and over. Dimensions 60 x 30 x 35 mm.
- DM and DN, for pipes from 10 to 750 mm. Dimensions 40 x 20 x 25 mm.
- Material stainless steel and PEEK.
- Temperature range, -10 to +80 degC standard, -20 to +130 degC extended.
- Ingress Protection rated IP66, with IP68 option.
- Cable length 3m as standard.
- Matched pairs for accurate zero flow measurement.

## 8.0 Product Identification

Each UFM and pair of flow transducers comes with a unique Identification code. This is printed in the lid to the screw terminal area.

In the case of the UFM this is also written into the software and can be read using the UI.

In the event of a need to contact Sonic Driver please have these codes available to quote.

## 9.0 Service

The UFM is a sophisticated measuring instrument and contains no user serviceable parts.

For all operational problems please contact our service department by telephone or email, see

Appendix A.

Sonic Driver do offer a software upgrade service. Please contact the factory for information about the latest software.

## **10.0 Limited Warranty and Disclaimer**

Sonic Driver Ltd warrants to the end purchaser, for a period of one year from the date of shipment from our factory, that all new products manufactured by it are free from defects in materials and workmanship.

This warranty does not cover products that have been damaged due to normal use, misapplication, abuse, lack of maintenance, or improper installation.

Sonic Driver obligation under this warranty is limited to the repair or replacement of a defective product, if the product is inspected by Sonic Driver Ltd and found to be defective. Repair or replacement is at the discretion of Sonic Driver Ltd.

If the product is outside of the warranty period a purchase order must be received from the end purchaser before repair work will start.

The product must be thoroughly cleaned and any contamination removed before it will be accepted for return.

The purchaser must determine the applicability of the product for its desired use and assumes all risks in connection therewith. Sonic Driver Ltd assumes no responsibility or liability for any omissions or errors in connection with the use of its products.

Sonic Driver Ltd will under no circumstances be liable for any incidental, consequential, contingent or special damages or loss to any person or property arising out of the failure of any product, component or accessory.

All expressed or implied warranties, including the implied warranty of merchantability and the implied warranty of fitness for a particular purpose or application are expressly disclaimed and shall not apply to any products sold or services rendered by Sonic Driver Ltd.

The above warranty supersedes and is in lieu of all other warranties, either expressed or implied and all other obligations or liabilities.

No agent or representative of Sonic Driver Ltd has any authority to alter the terms of this warranty in any way.

## Appendix A Contact Details

Telephone: +44(0)7971 273000

Postal Address: Sonic Driver Ltd, Lochiel, Llaneilian Road, Amlwch, Gwynedd, LL68 9HU, UK.

Email: [service@sonic-driver.com](mailto:service@sonic-driver.com)

Website: [www.sonic-driver.com](http://www.sonic-driver.com)

## Appendix B Table of fluid properties

Fluid	Longitudinal Speed of Sound (m/s)
Water 20 (degC)	1482
Acetone	1190
Methanol	1121
Ethanol	1166
Alcohol	1440
Glycerine	1923
Petrol	1250
Diesel	1385
Toluene	1170
Coal Oil	1420
Petroleum	1290
Pine Oil	1280
Castor Oil	1502
Glycol	1620
Peanut Oil	1472

## Appendix C Table of pipe and lining material properties

Material	Shear Speed of Sound (m/s)
Steel	3206
ABS	2286
Aluminium	3046
Copper	2270
Cast Iron	2460
GRP	3430
Glass	3276
PVC	2540
Cement	4190
Teflon	1450
Rubber	1600

## Appendix D Table of speed of sound in water

Temperature (degC)	Speed of Sound (m/s)
0	1402.3
5	1426.1
10	1447.2
15	1465.8
20	1482.3
25	1496.6
30	1509.0
35	1519.7
40	1528.8
45	1536.3
50	1542.5
55	1547.3
60	1550.9
65	1553.4
70	1554.7
75	1555.1
80	1554.4
85	1552.8
90	1550.4
95	1547.1
99	1543.9

## Appendix E Table of typical pipe roughness values

When a fluid flows through a pipe then the pipes own internal roughness is important when considering friction losses.

Pipe manufacturers often quote a pipe roughness value for their products.

Some typical figures are given below.

Pipe Material	Peak to Trough Roughness (mm)
Concrete	0.3 to 3.0
Cast Iron	0.26
Galvanized Iron	0.15
Asphalted Cast Iron	0.12
Commercial or Welded Steel	0.045
PVC, Glass and other drawn tubing	0.0015

By default the Sonic Driver flowmeter uses a figure of 0.01mm as a good compromise for most common pipes.

### Sonic Driver